

**Description**

The VPSL-0658-050-H-5-G is a 0.65  $\mu\text{m}$  band, AlGaInP index guided, laser diode with a multi-quantum well (MQW) structure. Its beam divergence has a small variation to the optical output power. The characteristic makes it possible to suppress the variation of spot size between higher and lower output powers. It is suitable as a light source for imaging, projection, large capacity optical disc memories, such as DVD-RAM, and various other types of optical equipment. Combined with an integrated, internal, beam correcting optic and encased in a hermetic sealed package, this is a high-performance, highly reliable, and long life laser diode.

**Features**

- Circular, diverging beam, NA approximately 0.11
- Diffraction limited wavefront, aberration equal or better than  $\lambda/4$  peak to valley
- 50mW (CW maximum) optical power, 70mW pulsed (50% duty, width=100ns)
- Standard 5.6 mm form factor

**Absolute Maximum Ratings** ( $T_C$ =case temperature=25°C) \*

Item	Symbol	Min	Max	Unit
Optical output power (CW)	$P_O$	-	50	mW
LD reverse voltage	$V_R$ (LD)	-	2	V
Operating temperature	$T_{opr}$	-10	+60	°C
Storage temperature	$T_{stg}$	-40	+85	°C

**Optical and Electrical Characteristics** ( $T_C$ =case temperature=25°C) \*

Item	Symbol	Min	Typ	Max	Unit	Test Conditions
Threshold current	$I_{th}$	30	45	60	mA	
Operating current	$I_{op}$	-	115	135	mA	$P_O=50\text{mW}$
Operating voltage	$V_{op}$	2.1	2.6	3.0	V	$P_O=50\text{mW}$
Optical output power	$P_O$	-	50	-	mW	Kink free
Lasing wavelength	$\lambda_p$	650	658	662	nm	$P_O=50\text{mW}$
Circularity	$\phi$		-	1.2:1.0	ratio	$P_O=50\text{mW}$
Beam divergence	$\theta$	7	8.5	11	deg	$P_O=50\text{mW}$ , FWHM
Astigmatism	$A_S$	-	-	0.25	waves	

- *Specifications are subject to change without notice. Each purchased CircuLaser is provided with test data. Please refer to this data before using the CircuLaser.*
- *This laser is the replacement for the discontinued PS110-00 Circulaser.*

# CircuLaser - Package Detail, Mechanical & Electrical – VPSL-0658-050-H-5-G

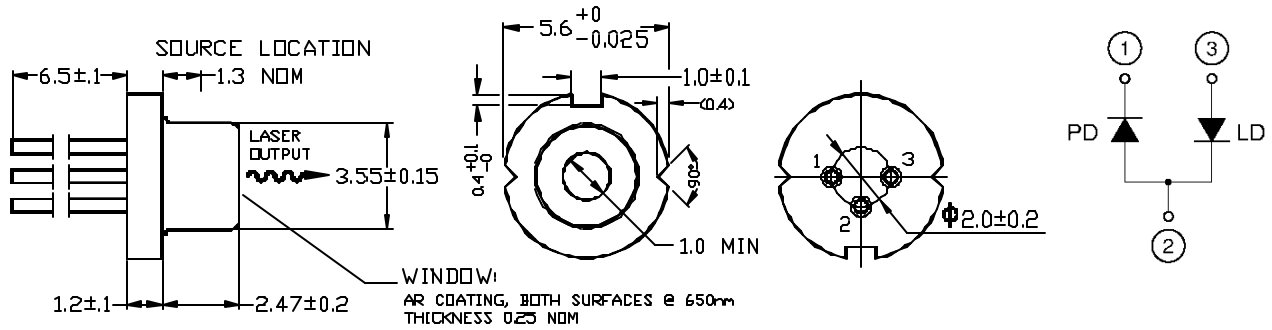

## Handling Care and Precautions for Use of CircuLaser Diodes

### 1. Absolute Maximum Ratings

Do not exceed, *even momentarily*, the maximum ratings (see page 1, table). When a CircuLaser diode is driven in excess of its maximum ratings, it can cause at minimum a considerable reduction in reliability, and potentially instantaneous failure.

- CircuLaser diodes may be damaged by surge currents generated at power on-off operation. Check on the transient characteristics of the power supply to make sure that such surges do not exceed the maximum ratings.
- The maximum ratings are specified for a case temperature of 25°C. Designs should be made to work well within this temperature range. As the case temperature goes up, power dissipation as well as maximum light output power is reduced.

### 2. Soldering Conditions

Maximum solder-tip temperature is 260°C and soldering time must be within 3.0 seconds. A minimum solder clearance of 1.6mm should be maintained from the root of the lead.

### 3. Prevention of Breakdown due to Static Electricity

CircuLaser diodes may be adversely affected by static electricity and surge currents and, consequently, cause breakdown of the diode and reduction of reliability unless the following precautions are taken:

- Power supplies, installation and measuring equipment should be grounded. A noise filter or noise-cut transformer should be provided on any power supply inputs.
- Anyone working with a CircuLaser diode should be grounded through high resistance (500 K Ohm - 1M Ohm) by means of a ground strap and wrist band (for example).
- Soldering irons should be grounded to protect laser diodes from voltage leaks.
- During operation of the CircuLaser diode, working clothes, hats, and shoes should be static-protected. Cotton-based clothing is preferred.
- Any container for carriage and storage should be static-protected.
- Avoid using laser diodes in an environment where high frequency surge currents may be generated by an inductive electric field (such as a fluorescent lamp). These fields can also cause breakdown or deterioration of the laser diode.

### 4. Package Handling

- The laser diode package should not be cut off, reworked, or deformed. Do not hold the cap of the CircuLaser diode tightly, otherwise it may induce cracks or damage to the window glass.
- Do not touch the surface of the window glass. Any scratch or contamination may result in reduction of optical characteristics.
- Remove small contaminants on the surface softly using a cotton tip stick with a small amount of methyl alcohol.

### 5. Safety

The output light from laser diodes is harmful to a human body even if it is invisible. Avoid looking at the output light of a CircuLaser diode directly, or even indirectly through a lens during operation. Observance of operation should be through an infrared TV camera or related equipment. Refer to IEC 825-1 and 21 CFR 1040.10-1040.11 as a radiation safety standard for laser products.

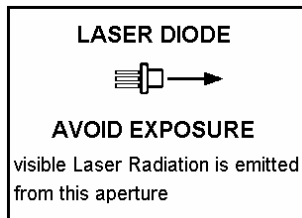

BSR165 5/10/2005