

FiberTEC635™

635nm Laser Module
25mW, 10mW or 5mW
With
Integrated Drive, Power & Wavelength
Electronics



Features

The FiberTEC635™ laser module features a temperature stabilized, fiber coupled, high output power 635nm laser diode and integrated drive electronics. The standard module includes a thermo-electric cooler (TEC), and electronics for automatic Power Control (APC) and Automatic Current Control (ACC). The FiberTEC635™ package footprint measures 71.1x23.9x15.2mm, and incorporates a 1-meter, single mode optical fiber output.

Performance

The FiberTEC635™ module can be configured in either ACC or APC mode of operation via a simple jumper connection. Power outputs available include; 5mW, 10mW, and 25mW. Laser output via a single mode, 0.13 NA fiber optic pigtail, optimizes beam steer stability, and provides the flexibility of remote laser beam delivery. In addition, the FiberTEC635™ module includes monitoring, control and protection circuits.

The FiberTEC635™ utilizes a TEC to gain several distinct advantages over traditional LD modules. The FiberTEC635™ TEC provides stabilized laser power output over widely varying temperatures. Power stability is < 0.75% long term (<24hrs), and <0.25% short term (1hr). Additionally, the FiberTEC635™ TEC also eliminates spectral shift with temperature, minimizes laser mode hopping, and simultaneously extends laser lifetime (by maintaining laser operation at one temperature).

Options

Custom configurations are available and include; user controllable temperature settings, various power outputs, and wavelength options of 405, or 658. Output options include; polarization maintaining fiber (typical extinction ratio of 100:1) and bare fiber. Termination options include fiber connectorization or collimated beams with diameters of 0.9 mm, 1.25 mm, or 2.5 mm, or a user specified diameter.

Applications

- * Spectroscopy
- * Printing
- * Particle scattering/sizing
- * Confocal Microscopy
- * Pointing & Alignment
- * Flow Cytometry



FiberTEC635™

Optical Specifications (T_{A=25}):

Power Output (P _{out}):	5mW, 10mW, 25mW
Wavelength,	635nm +7 / -2 nm
Polarization	Random
Power Stability	1hr, <0.25%
	24hrs, <0.75%
Noise: RMS, 20Hz – 20MHz	< 0.3%
: P-P, 20Hz – 20MHz	< 1.0%
Beam Stability	<5μrad (8hrs)
M2	<1.1
Fiber Type	SM, 125μm clad, 3mm buffering
Fiber NA	0.13
Mode field Dia.	4.0 +/- 0.5 μm Typ.
Fiber connector	FC/PC, (SC optional)

Typical Performance Curves

Long Term Laser Stability in APC mode
% Change P_{out} vs. Time

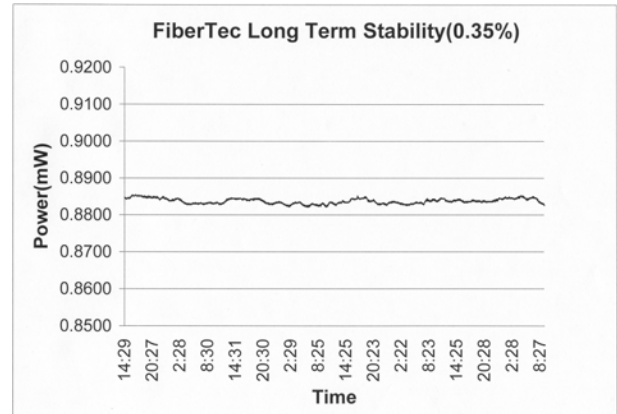

Electrical Specifications

Input	3.3 and 5Vdc +/- 5%
-------	---------------------

Environmental Specifications

Cooling:	TEC
Operating Temp:	0-40° C
Storage Temp:	0 to 70°C

Options:

- Beam collimators: 0.9, 1.5, 2.5
- Beam Divergence (full angle):
 - 0.9 & 1.5 collimator = 1mrad
 - 2.5 collimator = 0.5 mrad
- PM fiber: 100:1 extinction ratio
- PCB Mounting Pins

Mechanical Layout

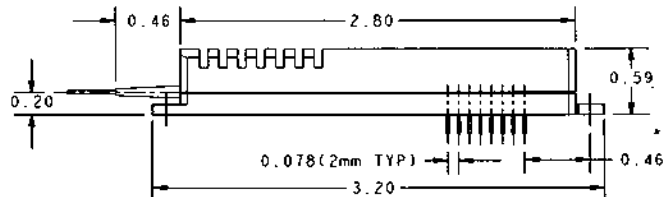
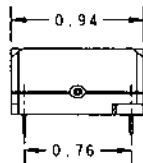
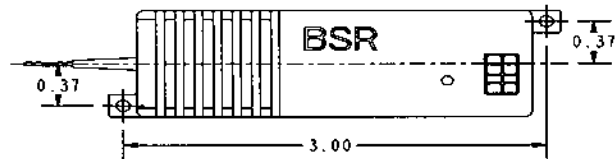
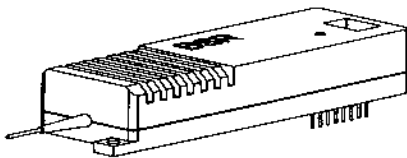

Note: Mounting Hole size = M2
Electrical pin dia. = 0.45mm +/- 0.1

FiberTEC635™

Electrical Pin Out

Pin No.	Name	Type	Description
1	NC	Passive	No connection
2	NC	Passive	No connection
3	GND	Active	Ground
4	Set	Analog input	Constant current or constant power setting, Max 1.2V
5	VTEC	Analog Output	Indicates Relative Voltage Across TEC, 1.5V correspond to 0V across TEC, 3.0V indicates Max.
6	APC	Active	Connect to Pin 8, Automatic Power Control.
7	ACC	Active	Connect to Pin 8, Constant Current Control.
8	CC	Active	Control common
9	Vcc	Power	5V +/- 5% Laser Driver Voltage
10	GND	Active	Ground
11	Temp. Set	Active	Temperature Setting Input (option).
12	TempRange	Digital Output	Indicates when Thermistor Temperature is within +/-0.1C of Target Temperature.
13	Alarm	Digital Output	Indicate OPEN OR Short Circuit from the Thermistor.
14	GND	Active	TEC Voltage ground
15	NC	Passive	No connection
16	VT	Active	3.3V or 5V +/-10% TEC Voltage

Electrical Configurations

ACC CONNECTIONS

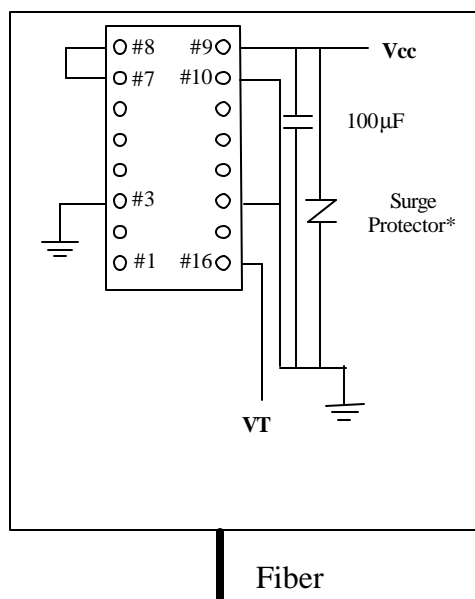

APC CONNECTIONS

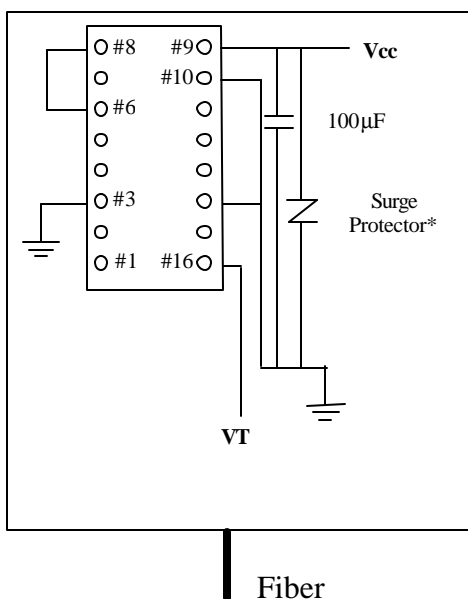

* Panasonic ERZ-V0D180

FTEC ORDERING INFORMATION

FTEC - □□□□ - □□□□ - □ - □□

Product Family _____

Wavelength, (nm) _____
0405, 0635, 0658

PinOut Configuration _____
0 = no pins on bottom, P = PCB pins

Power Output (mW) _____
05, 10, 15, 20*, 25*

Fiber Type _____
S = single mode
P = polarization maintaining

Fiber Connector _____
FC/PC = F FC/APC = A SC/PC = S SC/APC = G

Collimator _____
None = 0, 1mm = M, 1.5mm = N, 2.5mm = P**, 4.0mm = Q

* FTEC405 to 15mW only
** FTEC405 has 2.0 mm collimator offered as option P

Example: FTEC-0635-P25-S-F0, FiberTEC635™ laser module with 635nm Laser diode, PCB pins on bottom of package, 25mW power output, single mode fiber, FC/PC fiber connector, and no collimated beam output optics

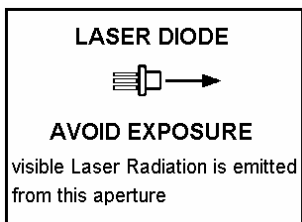

This component does not comply with the Federal Regulations (21 CFR Subchapter 1) as administered by the Center for Devices and Radiological Health. Purchaser acknowledges that his/her products must comply with these regulations before they can be sold to a customer. The output light from laser diodes is harmful to a human body even if it is invisible. Avoid looking at the output light of a FiberTEC directly, or even indirectly through a lens during operation. Observation of operation should be through a TV camera or related equipment. Refer to IEC 825-1 and 21 CFR 1040.10-1040.11 as a radiation safety standard for laser products.

Blue Sky Research follows a policy of continuous improvement. Specifications are subject to change without notice.

Contact Information:

BLUE Sky Research * 1537 Centre Pointe Drive * Milpitas, CA 95035 * (408) 941-6068 * FAX (408) 941 - 6069
www.blueskyresearch.com * email: Sales @blueskyresearch.com